

# PROLUMIA®

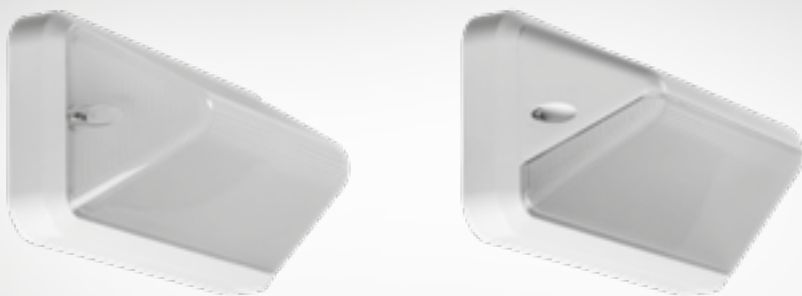

**LED PRO-FIT + LED PRO-FIT SEMI SHIELDED  
+ EMERGENCY MODE**



## OPERATING INSTRUCTION

GEBRUIKSAANWIJZING  
MANUEL D'UTILISATION  
INSTALAČNÍ NÁVOD  
GEBRAUCHSANLEITUNG

40010302	Pro-Fit + Emergency mode (White)
40010312	Pro-Fit + Emergency mode (Black)
40010303	Pro-Fit + Microwave sensor + Emergency mode (White)
40010313	Pro-Fit + Microwave sensor + Emergency mode (Black)
40010322	Pro-Fit Semi shielded + Emergency mode (White)
40010332	Pro-Fit Semi shielded + Emergency mode (Black)
40010323	Pro-Fit Semi shielded + Microwave sensor + Emergency mode (White)
40010333	Pro-Fit Semi shielded + Microwave sensor + Emergency mode (Black)

CE  IP66   8000K  
4000K

## ATTENTIE

Lees de volgende instructies zorgvuldig door om ervoor te zorgen dat de montagewerkzaamheden op de juiste manier worden uitgevoerd. Bewaar deze instructies goed voor eventueel toekomstig gebruik.

## OPGELET

1. Het product dient te worden geïnstalleerd door gekwalificeerde personen. De installatie dient, voorafgaand aan de montage, spanningsloos te worden gemaakt.
2. De installatiedraad moet minimaal 2 x 1,0 mm<sup>2</sup> zijn en worden aangesloten in overeenstemming met de laatste elektriciteitsvoorschriften van IEE of volgens de nationale eisen.
3. Sluit de stroomtoevoer van de voeding af voordat u de accu vervangt.
4. Raak het elektronische circuit en de componenten niet aan.
5. Indien de autonomie van 1 uur niet meer wordt gehaald, dient de accu vervangen te worden.
6. Neem contact op met een erkende technische service center voor het vervangen van de accu en gebruik alleen originele onderdelen voor andere reparaties.
7. Identificatie code van de accu productiedatum: ex.1810 --- 2018, week10.
8. Raak de LED's niet aan tijdens installatie of onderhoud.
9. De LED lichtbron van de lamp kan niet worden vervangen. Het volledige product dient te worden vervangen als de lichtbron defect is.
10. Door zelfontlading neemt de lading van de accu, als deze niet op het net is aangesloten, langzaam af. Dit kan leiden tot schade aan de accu bij langdurige spanningsloosheid. De hierdoor ontstane schade valt niet onder garantie.
11. Op veel bouwplaatsen kunnen stroomcircuits worden onderbroken op een ongecontroleerde en repetitieve basis tijdens de bouw. Accu's kunnen als gevolg hiervan leeglopen. Het frequent laden en ontladen van de accu zal de levensduur verkorten en kan leiden tot voortijdig falen van de accu. De hierdoor ontstane schade valt niet onder garantie.

## TECHNISCHE DATA

Voedingsspanning: AC 220-240V 50/60Hz

Lichtbron: SMD2835 LED

Accu: Ni-Cd Duur: 1 uur

Bedrijfstemperatuur: -10°C - +50°C (Sensor versie: tot max. +40°C)

Elektrische veiligheidsklasse: Klasse II

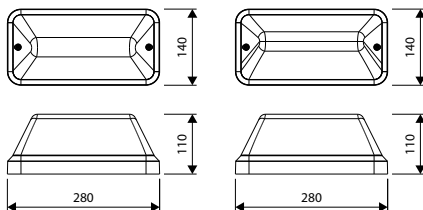

## TECHNISCHE INFORMATIE

### Standaard versie

Artikelnr.	Kleur	Vermogen	Lichtstroom schakelbaar	Sensor
40010302	Wit	7W	700Lm / 350Lm	-
40010312	Zwart	7W	700Lm / 350Lm	-
40010303	Wit	8W	700Lm / 350Lm	Ja
40010313	Zwart	8W	700Lm / 350Lm	Ja

### Half afgeschermd versie

Artikelnr.	Kleur	Vermogen	Lichtstroom schakelbaar	Sensor
40010322	Wit	7W	500Lm / 250Lm	-
40010332	Zwart	7W	500Lm / 250Lm	-
40010323	Wit	8W	500Lm / 250Lm	Ja
40010333	Zwart	8W	500Lm / 250Lm	Ja

## MICROWAVE SENSOR - BESCHRIJVING

Detectiebereik max. (D x H): 12m x 6m

Detectiegevoeligheid: 50% of 100%, instelbaar

Branduur: 5sec - 10min, instelbaar

Daglicht aan: 5 - 50Lux, instelbaar of uitgeschakeld

Daglicht uit: 25 - 150Lux, instelbaar of uitgeschakeld

Stand-by periode (laag lichtniveau): 0 sec - +∞, instelbaar

Stand-by dim niveau: 10% of 25%, instelbaar

Montagehoogte plafond: 6m max.

Bewegingsdetectie (drempel): 0,3 ~ 3m/s

Detectiehoek: 150° (wandmontage),

360° (plafondmontage)

Detectiebereik (m) wandmontage  
Voorgestelde montagehoogte: 2m

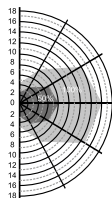

Bewegingssnelheid: 0,3m/s

Detectiebereik (m) plafondmontage  
Voorgestelde montagehoogte: 3m

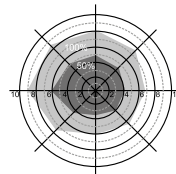

Bewegingssnelheid: 0,3m/s

## MICROWAVE SENSOR - INSTELLING PARAMETERS

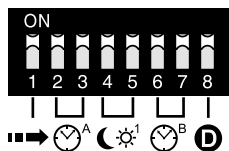

### Detectiebereik

Dit bepaalt het effectieve bereik van de bewegingsmelder en wordt met de micro-schakelaars op de driver ingesteld. Wees er van bewust dat het verminderen van de gevoeligheid ook het detectiebereik zal verkleinen.

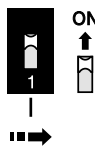

	1	
I	ON	100%
II	—	50%

### Nalooptijd

Dit bepaalt de tijd dat het armatuur op 100% niveau blijft branden. Dit kan worden ingesteld met micro-schakelaars op de driver. Tijdens het installeren van het armatuur is de looptest-instelling (5s) handig om de juiste werking en het bereik vast te stellen.

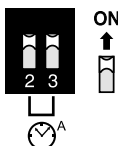

	2	3	
I	ON	ON	5s
II	ON	—	1min
III	—	ON	5min
IV	—	—	10min

### Daglicht

Met deze instelling kan worden bepaald bij welk daglichtniveau het armatuur al/dan niet zal worden ingeschakeld bij bewegingsdetectie. De fotocel functionaliteit kan ook worden uitgeschakeld.

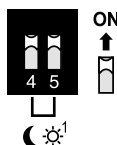

	4	5	ON	OFF
I	ON	ON	5Lux	25Lux
II	ON	—	25Lux	75Lux
III	—	ON	50Lux	150Lux
IV	—	—	Disable	Disable

### Stand-by periode

Bij de +∞ instelling zal het armatuur gedimd gaan branden op basis van de instelling bij ☀<sup>1</sup> en de hoeveelheid omgevingslicht. Bij bewegingsdetectie gaat het lichtniveau gedurende de nalooptijd naar 100%.

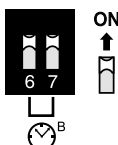

	6	7	
I	ON	ON	0s
II	ON	—	10min
III	—	ON	30min
IV	—	—	+∞

### Stand-by Dim niveau

Instelling van de lichtstroom bij gedimd lichtniveau.

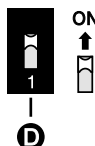

	8	
I	ON	10%
II	—	25%

Als de DIP-schakelaar op 'Stand-by periode' op +∞ staat, is de standaardinstelling 10% en kan niet worden gewijzigd.

NL

EN

FR

CZ

DE

# MICROWAVE SENSOR - VOORBEELDEN VAN INSTELLINGEN

## A 0% / 100% / 10% of 25%

Uit bij voldoende omgevingslicht --> 's-avonds/'s-nachts na bewegingsdetectie 100% gedurende nalooptijd  
en 10%/25% gedurende stand-by tijd --> daarna uit

**1**

Uit bij voldoende daglicht, ook na detectie.

**2**

100% gedurende nalooptijd, bij detectie en onvoldoende daglicht.

**3**

Na afloop nalooptijd naar 10%/25% gedurende stand-by tijd.

**4**

Uit na afloop stand-by tijd.



### Stand-by periode (gedimd licht)

ON ↑

⌚<sup>B</sup>

	6	7	
I	ON	ON	0s
II	ON	—	10min
III	—	ON	30min
IV	—	—	+∞



### Daglicht

ON ↑

☀️<sup>1</sup>

	4	5	ON	OFF
I	ON	ON	5Lux	25Lux
II	ON	—	25Lux	75Lux
III	—	ON	50Lux	150Lux
IV	—	—	Disable	Disable



## B 0% / 100%

Uit bij voldoende omgevingslicht --> 's-avonds/'s-nachts na bewegingsdetectie 100% gedurende nalooptijd --> daarna uit

**1**

Uit bij voldoende daglicht, ook na detectie.

**2**

100% gedurende nalooptijd, bij detectie en onvoldoende daglicht.

**3**

Uit na afloop nalooptijd.



### Stand-by periode (gedimd licht)

ON ↑

⌚<sup>B</sup>

	6	7	
I	ON	ON	0s
II	ON	—	10min
III	—	ON	30min
IV	—	—	+∞



### Daglicht

ON ↑

☀️<sup>1</sup>

	4	5	ON	OFF
I	ON	ON	5Lux	25Lux
II	ON	—	25Lux	75Lux
III	—	ON	50Lux	150Lux
IV	—	—	Disable	Disable



## MICROWAVE SENSOR - VOORBEELDEN VAN INSTELLINGEN

### C 10% / 100%

Altijd aan op gedimd niveau --> na detectie 100% gedurende nalooptijd

**1**

Overdag: gedimd niveau.

**2**

'S-avonds/'s-nachts:  
gedimd niveau.

**3**

100% gedurende nalooptijd,  
bij detectie.

**Stand-by periode** (gedimd licht)

ON ↑

	6	7	
I	ON	ON	0s
II	ON	—	10min
III	—	ON	30min
IV	—	—	+∞

✓

**Daglicht**

ON ↑

	4	5	ON	OFF
I	ON	ON	5Lux	25Lux
II	ON	—	25Lux	75Lux
III	—	ON	50Lux	150Lux
IV	—	—	Disable	Disable

✓

### D 0% / 10% op basis van daglicht / 100% bij beweging

Gedimd niveau aan/uit op basis van daglicht en 100% bij detectie

**1**

Uit bij voldoende daglicht,  
ook na detectie.

**2**

'S-avonds/'s-nachts:  
aan op gedimd niveau.

**3**

100% gedurende nalooptijd,  
bij detectie.

**5**

Uit bij voldoende daglicht,  
ook na detectie.

**4**

'S-avonds/'s-nachts:  
aan op gedimd niveau.

**Stand-by periode** (gedimd licht)

ON ↑

	6	7	
I	ON	ON	0s
II	ON	—	10min
III	—	ON	30min
IV	—	—	+∞

✓

**Daglicht**

ON ↑

	4	5	ON	OFF
I	ON	ON	5Lux	25Lux
II	ON	—	25Lux	75Lux
III	—	ON	50Lux	150Lux
IV	—	—	Disable	Disable

✓  
✓  
✓

## MASTER/SLAVE FUNCTIE

### Functie A

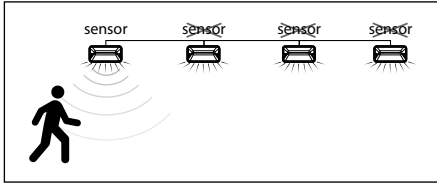

### Functie B

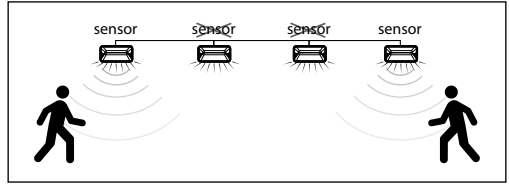

#### Functie A - Centraal geschakeld

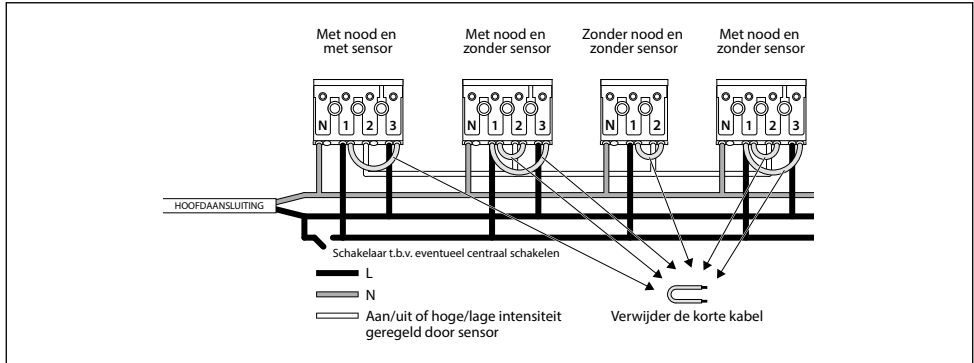

#### Functie B - Alleen geschakeld d.m.v. ingebouwde sensoren

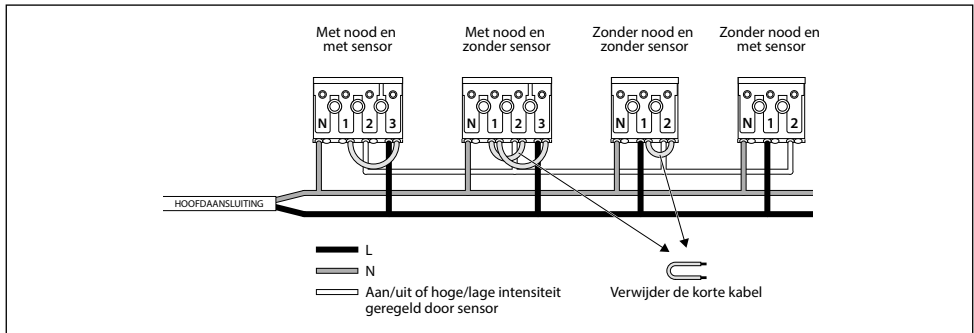

**Het aantal units in slave-functie is gelimiteerd. (Max. 30 stuks)**

## KEUZE LICHTKLEUR

U kunt het armatuur instellen op 2 verschillende lichtkleuren. De schakelaar is te vinden op de LED module en is te zien wanneer u de beschermingskap heeft verwijderd.

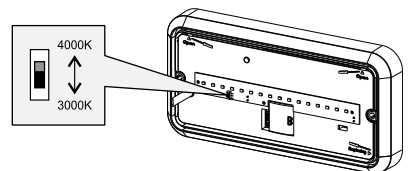

## KEUZE LICHTOPBRENGST

U kunt het armatuur instellen op 2 verschillende Lumen waarden:

- ON - 100% (standaard)
- 1 - 50%

De schakelaar is te vinden naast de LED module en is te zien wanneer u de beschermingskap heeft verwijderd.

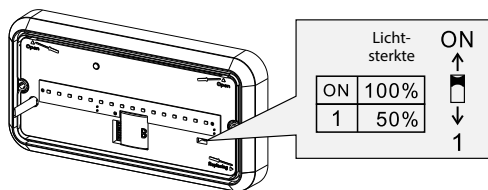

## MONTAGE

1. Draai de afscherming los en open het LED paneel.
2. Haal het aansluitsnoer door de thule en fixeer met de trekontlasting.
3. Bevestig het armatuur d.m.v. schroeven op de ondergrond.  
(Let op de richting. Dit is aangegeven met de markering 'UP' op de basis van het armatuur.)
4. Sluit het aansluitsnoer correct aan op de terminal.
5. Sluit de stekker van de accu aan op de "Battery +/-" aansluiting van de noodunit.
6. Sluit het LED paneel en bevestig de afscherming.

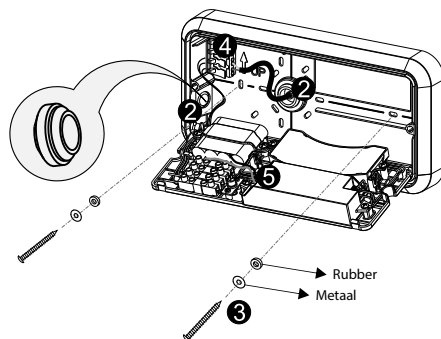
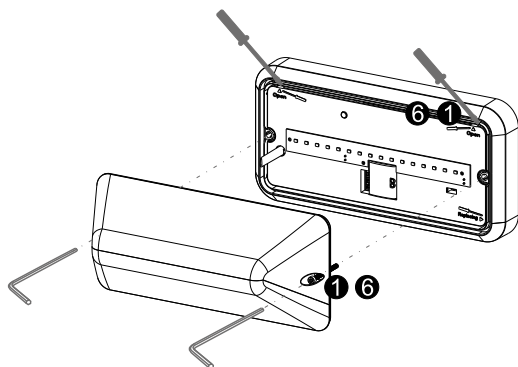

### 4 Aansluiting kabel

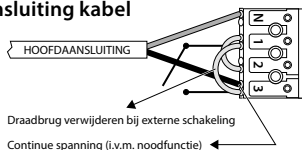

**Nood versie**

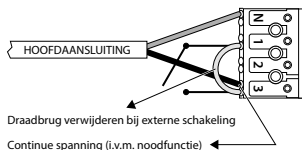

**Nood + Sensor versie**  
(geschakelde fase niet verplicht)

## TESTEN

Test noodfunctie na de installatie.

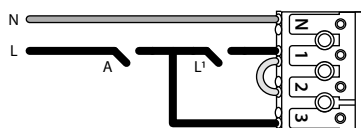

- L, N = Continue voeding
- L' = Geschakelde voeding
- A = Controle noodfunctie

## ACCU VERVANGEN

1. Maak het armatuur eerst spanningsloos.
2. Trek de plug van de accu uit de noodunit.
3. Verwijder de plastic bevestigingen.
4. Verwijder de oude accu.
5. Noteer de datum van ingebruikname van de accu.
6. Bevestig de nieuwe accu d.m.v. de plastic bevestigingen.
7. Sluit de stekker aan op de noodunit.

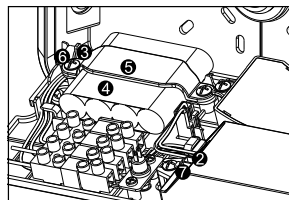

## BINNENWERK VERVANGEN

 **Maak het armatuur eerst spanningsloos.**

1. Maak de beschermkap los, verwijder daarna met een schroevendraaier de LED driver.
2. Haal de male-female-stekkers van elkaar en verwijder het oude binnenwerk.
3. Monteer het nieuwe binnenwerk en sluit vervolgens de male-female-stekkers stevig aan.
4. Bevestig de beschermkap.

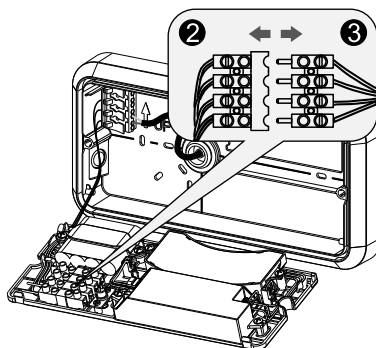
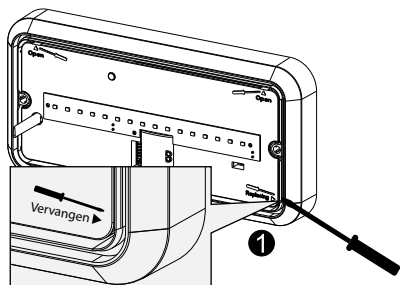

## ONDERHOUD

1. Maak het armatuur spanningsloos.
2. Raak de LED's niet aan tijdens onderhoud of schoonmaak.
3. Gebruik geen chemische schoonmaakmiddelen om de lamp te reinigen.

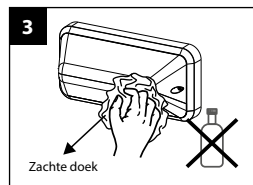
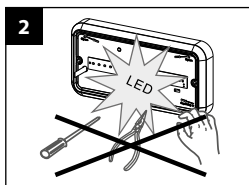
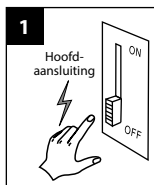

## BESCHERMING VAN HET MILIEU

Defecte elektrische apparaten behoren niet te worden weggegooid bij het huishoudelijk afval. Recycle waar mogelijk. Neem contact op met uw gemeente of uw leverancier voor een deskundig recycling advies.





## ATTENTION

Please read the following instructions carefully to ensure that mounting operation will be carried out correctly. These instructions should be properly preserved for future reference.

## CAUTION

1. The product must be installed by qualified technicians. The power supply must be cut before installation.
2. The installation wiring must be  $2 \times 1.0 \text{ mm}^2$  at least and wired in accordance with the latest IEE electrical regulations or the national requirements.
3. Cut the power supply before replacing battery.
4. Do not touch the electronic circuit and its components.
5. When fixture is unable to maintain the 1 hour duration under battery operation, then the battery must be replaced.
6. Contact an authorised technical service center for the replacement of the battery and use only original manufacturer spare parts for any other repairs.
7. Code for identification of battery production date: ex.1810 --- 2018, week10.
8. Do not touch the LEDs while installing or maintaining.
9. The LED light source of the lamp cannot be replaced. The complete product must be replaced if the light source is defect.
10. The charge of the battery will decrease by self-discharge if not connected to mains supply. Prolonged periods without voltage can damage the battery. Battery warranty claims, as a result of such abuse, are specifically EXCLUDED from warranty terms.
11. On many building sites, power circuits may be cut off in an uncontrolled and repetitive basis during construction. As a result, any unit on these circuits, will have their batteries discharged or 'cycled'. Excessive battery cycling will reduce through-life performance and may lead to premature battery failure. Battery warranty claims, as a result of such abuse, are specifically EXCLUDED from warranty terms.

## TECHNICAL DATA

Supply voltage: AC 220-240V 50/60Hz

Light source: SMD2835 LED

Batteries: Ni-Cd Duration: 1h

Operating temperature:  $-10^{\circ}\text{C} - +50^{\circ}\text{C}$  (Sensor version: upto max.  $+40^{\circ}\text{C}$ )

Electrical safety class: Class II

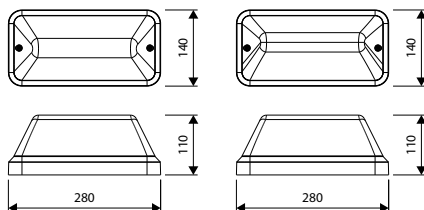

## TECHNICAL INFORMATION

### Standard version

Art. no.	Color	Input power	Lumen switchable	Sensor
40010302	White	7W	700Lm / 350Lm	-
40010312	Black	7W	700Lm / 350Lm	-
40010303	White	8W	700Lm / 350Lm	Yes
40010313	Black	8W	700Lm / 350Lm	Yes

### Semi shielded version

Art. no.	Color	Input power	Lumen switchable	Sensor
40010322	White	7W	500Lm / 250Lm	-
40010332	Black	7W	500Lm / 250Lm	-
40010323	White	8W	500Lm / 250Lm	Yes
40010333	Black	8W	500Lm / 250Lm	Yes

## MICROWAVE SENSOR - DESCRIPTION

Detection zone max. (d x h): 12m x 6m

Detection sensitivity: 50% or 100%, adjustable

Hold time: 5sec - 10min, adjustable

Daylight on: 5 - 50Lux, adjustable or disabled

Daylight off: 25 - 150Lux, adjustable or disabled

Stand-by period (low light level): 0 sec -  $+\infty$  min, adjustable

Stand-by dim level: 10% or 25%, adjustable

Ceiling mounting height: 6m max.

Motion detection (threshold): 0.3 ~ 3m/s

Detection angle:  $150^{\circ}$  (wall installation),

$360^{\circ}$  (ceiling installation)

Wall mounting detection area (m)  
Suggested installation height: 2m

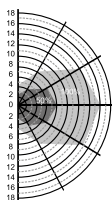

Walking speed: 0,3m/s

Ceiling mounting detection area (m)  
Suggested installation height: 3m

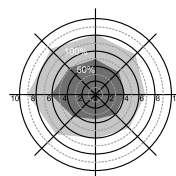

Walking speed: 0,3m/s

## MICROWAVE SENSOR - PARAMETER SETTINGS

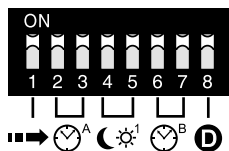

### ➡ Detection Area

This determines the effective range of the motion detector and is set with DIP switches on the driver. Note that reducing the sensitivity will also narrow the detection range.

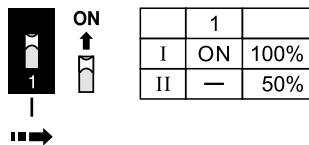

### 🕒<sup>A</sup> Hold Time

This determines the time the fixture remains at 100% and is set with DIP switches on the driver. The walk test (5s) setting is useful when installing the fixture to establish correct operation and range.

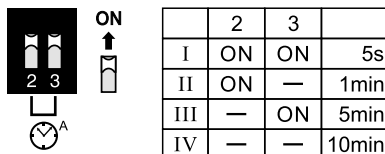

### ☀<sup>1</sup> Daylight

With this setting it can be determined at what daylight level the luminaire will or will not be switched on when motion is detected. The photocell functionality can also be disabled.

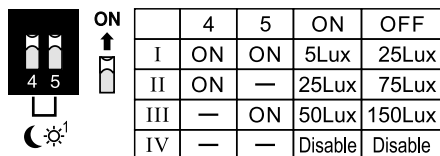

### 🕒<sup>B</sup> Stand-by period

With the +∞ setting, the fixture will light up dimmed based on the setting of ☀<sup>1</sup> and the amount of ambient light. With motion detection, the light level goes to 100% during the hold time.

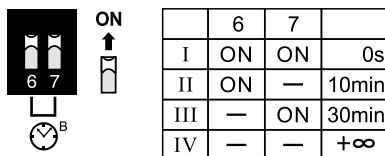

### ⓓ Stand-by Dim level

Adjustment of the luminous flux with dimmed light level.

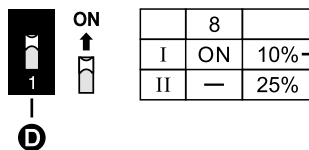

When the DIP switch is set to +∞ on 'Stand-by period', the default setting is 10% and can't be changed.

## MICROWAVE SENSOR -EXAMPLES OF SETTINGS

### A 0% / 100% / 10% or 25%

Off with sufficient ambient light --> in the evening / at night after motion detection 100% during hold time and 10% / 25% during stand-by time --> then off

**1**

Off with sufficient daylight, even after detection.

**2**

100% during hold time, upon detection and insufficient daylight.

**3**

After hold time to 10%/25% during stand-by time.

**4**

Off after the end of standby time.

**Stand-by period** (dimmed light)

	6	7	
I	ON	ON	0s
II	ON	—	10min
III	—	ON	30min
IV	—	—	+∞

**Daylight**

	4	5	ON	OFF
I	ON	ON	5Lux	25Lux
II	ON	—	25Lux	75Lux
III	—	ON	50Lux	150Lux
IV	—	—	Disable	Disable

### B 0% / 100%

Off with sufficient ambient light --> in the evening / at night after motion detection 100% during hold time --> then off

**1**

Off with sufficient daylight, even after detection.

**2**

100% during hold time, upon detection and insufficient daylight.

**3**

Off after hold time.

**Stand-by period** (dimmed light)

	6	7	
I	ON	ON	0s
II	ON	—	10min
III	—	ON	30min
IV	—	—	+∞

**Daylight**

	4	5	ON	OFF
I	ON	ON	5Lux	25Lux
II	ON	—	25Lux	75Lux
III	—	ON	50Lux	150Lux
IV	—	—	Disable	Disable

## MICROWAVE SENSOR - EXAMPLES OF SETTINGS

### C 10% / 100%

Always on at dimmed level --> after detection 100% during hold time

**1**

Daytime: dimmed level.

**2**

In the evening/at night:  
dimmed level.

**3**

100% during hold time,  
upon detection.



#### Stand-by period (dimmed light)



	6	7	
I	ON	ON	0s
II	ON	—	10min
III	—	ON	30min
IV	—	—	+∞



#### Daylight



	4	5	ON	OFF
I	ON	ON	5Lux	25Lux
II	ON	—	25Lux	75Lux
III	—	ON	50Lux	150Lux
IV	—	—	Disable	Disable



### D 0% / 10% based upon daylight / 100% when triggered

Dimmed level on/off based on daylight and 100% on detection

**1**

Off with sufficient daylight,  
even after detection.

**2**

In the evening/at night:  
on at dimmed level.

**3**

100% during hold time,  
upon detection.

**4**

In the evening/at night:  
on at dimmed level.

**5**

Off with sufficient daylight,  
even after detection.



#### Stand-by period (dimmed light)



	6	7	
I	ON	ON	0s
II	ON	—	10min
III	—	ON	30min
IV	—	—	+∞



#### Daylight



	4	5	ON	OFF
I	ON	ON	5Lux	25Lux
II	ON	—	25Lux	75Lux
III	—	ON	50Lux	150Lux
IV	—	—	Disable	Disable



## MASTER/SLAVE FUNCTION

### Function A

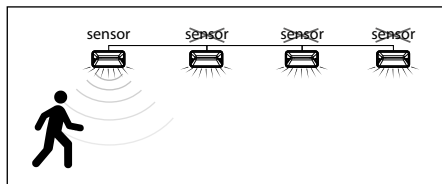

### Function B

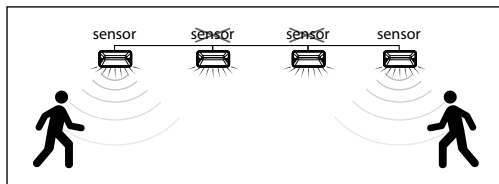

### Function A - Central switched

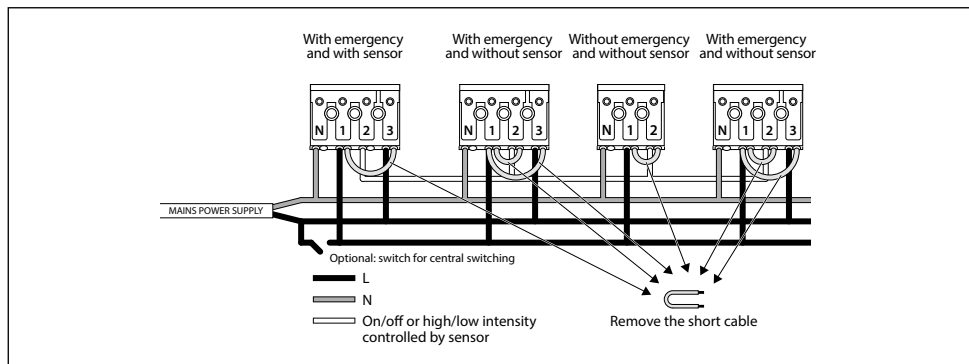

### Function B - Only switched by means of built-in sensors

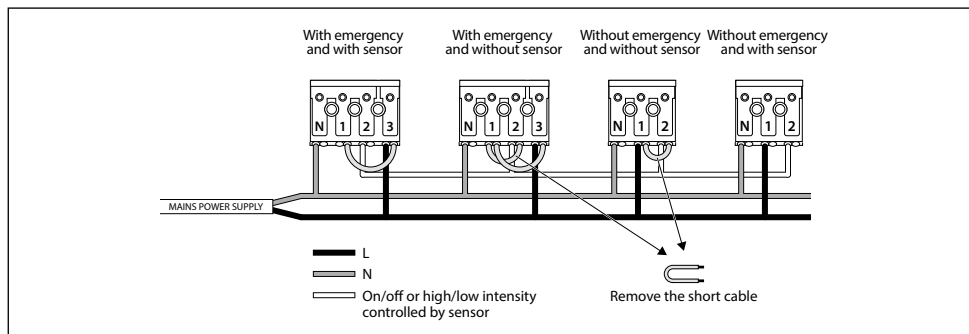

**⚠ The number of slaves is limited. (Max. 30pcs)**

## SELECTABLE COLOR TEMPERATURE

There are 2 choices of color temperature by different setting on the surface of the LED light engine.

The switch can be found on the LED module and can be seen when you have removed the protective cap.

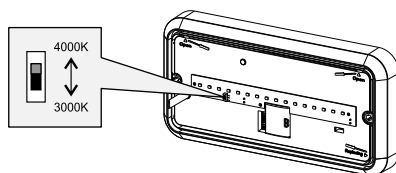

## SELECTABLE OUTPUT BRIGHTNESS

There are two choices of output brightness by different setting on the surface of the LED light engine:

- ON - 100% (standard)
- 1 - 50%

The switch can be found next to the LED module and can be seen when you have removed the diffuser.

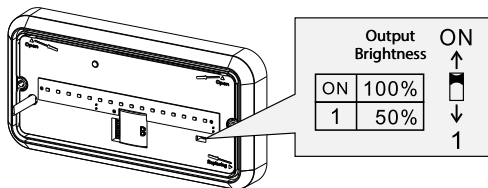

## MOUNTING

1. Disassemble the diffuser and LED panel.
2. Pull the power cord through the gasket.
3. Fix the fixture on the surface with screws.  
(Pay attention to the direction. This is indicated by the "UP" marking on the base of the fixture.)
4. Connect the power cord on the terminal correctly.
5. Connect the plug of the battery firmly onto the emergency driver. 
6. Assemble the LED panel and diffuser.

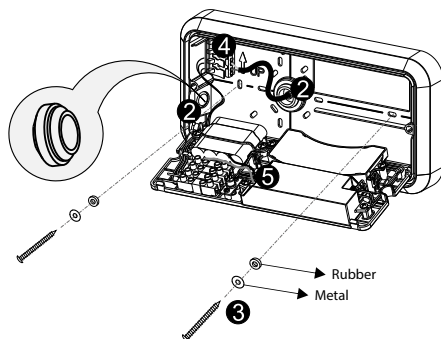
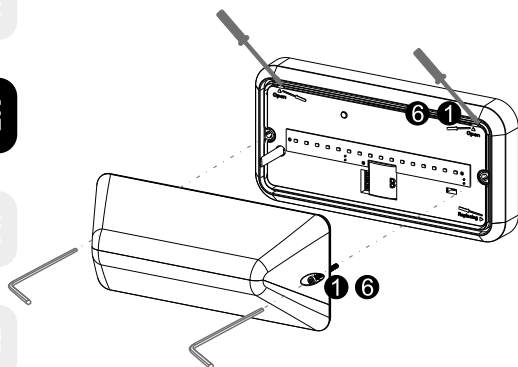

### 4 Cable connection

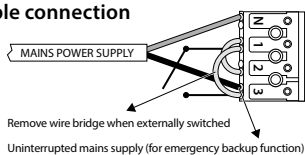

Emergency mode version

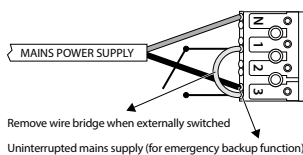

Emergency mode + Sensor version  
(switched phase not required)

## TESTING

Test emergency function after installation.

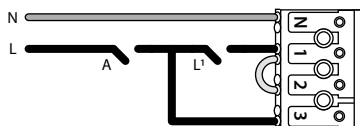

- L, N = Un-switched line
- L' = Switched line
- A = Test emergency operation

## HOW TO REPLACE BATTERIES

1. Cut the power supply first.
2. Pull out the plug of batteries from the emergency driver.
3. Screw out the plastic fixers.
4. Remove the old batteries.
5. Record the date of commissioning of the batteries.
6. Fix the new batteries by plastic fixers.
7. Connect the plug onto the emergency driver.

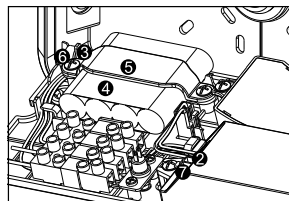

## REPLACING THE LIGHT ENGINE

 **Cut off the mains power first.**

1. Open the diffuser, then remove the LED light engine using tool.
2. Separate the male-female terminals, and remove the old light engine.
3. Assemble the new light engine, then connect the male-female terminals firmly.
4. Fix the diffuser.

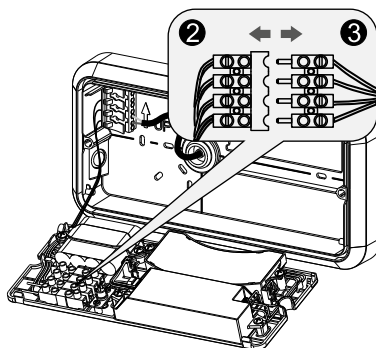
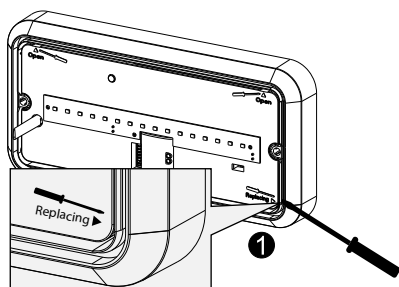

## MAINTENANCE

1. Cut off the mains power first.
2. Don't touch LED while maintaining or cleaning.
3. Don't use chemical reagent to clean lamp.

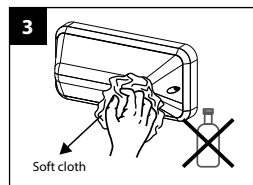
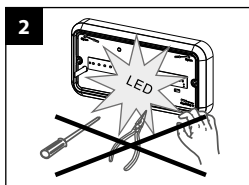
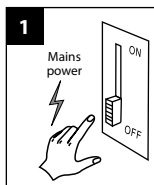

## ENVIRONMENTAL PROTECTION

Waste electrical products should not be disposed of with household waste. Please recycle where facilities exist. Check with your local authority or retailer for recycling advice.



## ATTENTION

Lisez attentivement les instructions suivantes pour vous assurer que les travaux d'installation sont effectués correctement. Conservez ces instructions en toute sécurité pour une utilisation future possible.

## ATTENTION

- Le produit doit être installé par des personnes qualifiées. L'installation doit être mise hors tension avant l'installation.
- Le câble d'installation doit avoir au moins 2 x 1,0 mm<sup>2</sup> et doit être raccordé conformément aux dernières réglementations électriques de l'IEE ou selon les exigences nationales.
- Débranchez l'alimentation avant de remplacer la batterie.
- Ne touchez pas le circuit électronique et les composants.
- Si l'autonomie de 1 heure n'est plus atteinte, la batterie doit être remplacée.
- Contactez un centre de service technique reconnu pour remplacer la batterie et n'utilisez que des pièces d'origine pour d'autres réparations.
- Code d'identification de la date de production de la batterie: ex.1810 --- 2018, semaine10.
- Ne touchez pas les voyants pendant l'installation ou la maintenance.
- La source de lumière LED de la lampe ne peut pas être remplacée. Le produit complet doit être remplacé si la source lumineuse est défectueuse.
- En se déchargeant automatiquement, la charge de la batterie, si elle n'est pas connectée au secteur, diminue lentement. Cela peut entraîner des dommages à la batterie pendant une période de sans tension prolongée. Les dommages qui en résultent ne sont pas couverts par la garantie.
- Sur de nombreux sites de construction, les circuits de courant peuvent être interrompus de manière incontrôlée et répétitive pendant la construction. En conséquence, les batteries peuvent se décharger. La charge et la décharge fréquente de la batterie réduiront sa durée de vie et entraîneront une défaillance prématurée de la batterie. Les dommages qui en résultent ne sont pas couverts par la garantie.

## DONNÉES TECHNIQUES

Tension d'alimentation: AC 220-240V 50/60Hz

Source de lumière: SMD2835 LED

Batterie: Ni-Cd Durée: 1 heure

Température de fonctionnement: -10°C - +50°C

(Version capteur: jusqu'à max. +40°C)

Classe de protection électrique: Classe II

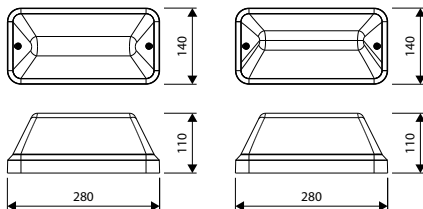

## INFORMATIONS TECHNIQUES

### Version standard

Numéro article	Couleur	Puissance	Le flux lumineux peut être commuté	Capteur
40010302	Blanc	7W	700Lm / 350Lm	-
40010312	Noir	7W	700Lm / 350Lm	-
40010303	Blanc	8W	700Lm / 350Lm	Oui
40010313	Noir	8W	700Lm / 350Lm	Oui

### Version semi-blindée

Numéro article	Couleur	Puissance	Le flux lumineux peut être commuté	Capteur
40010322	Blanc	7W	500Lm / 250Lm	-
40010332	Noir	7W	500Lm / 250Lm	-
40010323	Blanc	8W	500Lm / 250Lm	Oui
40010333	Noir	8W	500Lm / 250Lm	Oui

## CAPTEUR DE MICRO-ONDES - DESCRIPTION

Plage de détection maxi (D x H): 12m x 6m

Sensibilité de détection: 50% ou 100%, réglable

Temps de combustion: 5sec - 10min, réglable

Lumière du jour: 5 - 50Lux, réglable ou désactivé

Lumière du jour désactivé: 25 - 150Lux, réglable ou désactivé

Période de stand-by (faible niveau de lumière):

0 sec - +∞, réglable

Niveau d'atténuation stand-by: 10% ou 25%, réglable

Hauteur de montage plafond: 6m max.

Détection de mouvement (seuil): 0,3 ~ 3m/s

Angle de détection: 150° (montage mural),

360° (montage au plafond)

Portée de détection (m) montage au plafond  
Hauteur de montage proposée: 3m

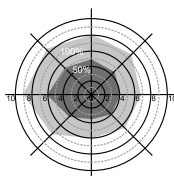

Vitesse de mouvement: 0,3m/s

Portée de détection (m) montage mural  
Hauteur de montage proposée: 2m

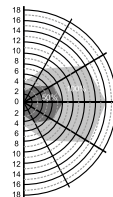

Vitesse de mouvement: 0,3m/s



## CAPTEUR DE MICRO-ONDES - RÉGLAGE DES PARAMÈTRES

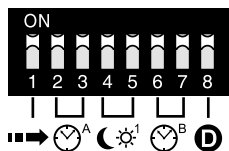

### Plage de détection

Ceci détermine la portée effective du détecteur de mouvement et est réglé avec les micro-interrupteurs sur le pilote. Rendez-vous compte que réduire la sensibilité réduira également la plage de détection.

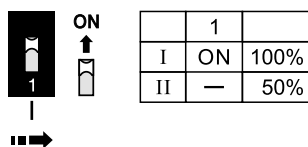

### Temps de rodage

Cela détermine le temps pendant lequel le luminaire reste allumé au niveau de 100%. Cela peut être réglé avec des micro-interrupteurs sur le pilote. Lors de l'installation du luminaire, le réglage du test de marche (5s) est utile pour déterminer le fonctionnement et la portée corrects.

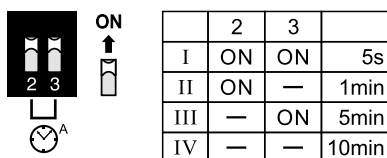

### Lumière de jour

Avec ce réglage, il est possible de déterminer à quel niveau de lumière du jour le luminaire s'allumera ou ne sera pas allumé lorsqu'un mouvement est détecté. La fonctionnalité photocellule peut également être désactivée.

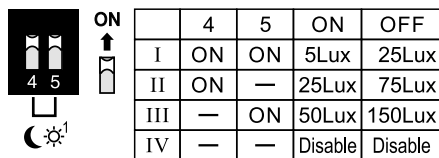

### Période de stand-by

Avec le réglage +∞, le luminaire s'allumera en atténuation en fonction du réglage ☀<sup>1</sup> et de la quantité de lumière ambiante. Avec la détection de mouvement, le niveau de lumière passe à 100% pendant le temps de rodage.

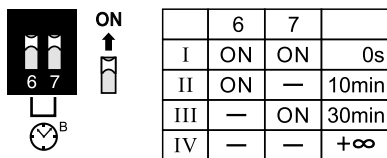

### D Niveau d'atténuation stand-by

Réglage du flux lumineux avec un niveau de lumière atténuée.

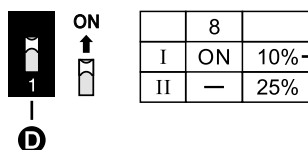

Lorsque le commutateur DIP est réglé sur +∞ sur 'Période stand-by', le réglage par défaut est 10% et ne peut pas être modifié.

## CAPTEUR MICROWAVE - EXEMPLES DE PARAMETRES

### A 0% / 100% / 10% ou 25%

Éteint en cas de lumière ambiante suffisante -> soir / nuit après détection de mouvement 100% pendant le temps de rodage et 10% / 25% pendant le temps de stand-by -> puis éteint

**1**



Éteint en cas de lumière du jour suffisante, même après détection.

**2**



100% pendant le temps de rodage, en cas de détection et de lumière du jour insuffisante.

**3**



Après le temps de rodage à 10% / 25% pendant le temps de stand-by.

**4**

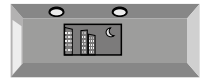

Éteint après temps de stand-by.



#### B Période de stand-by (lumière atténuée)



	6	7	
I	ON	ON	0s
II	ON	—	10min
III	—	ON	30min
IV	—	—	+∞



#### Lumière de jour



	4	5	ON	OFF
I	ON	ON	5Lux	25Lux
II	ON	—	25Lux	75Lux
III	—	ON	50Lux	150Lux
IV	—	—	Disable	Disable



### B 0% / 100%

Éteint en cas de lumière ambiante suffisante -> soir / nuit après détection de mouvement 100% pendant le temps de rodage -> puis éteint

**1**

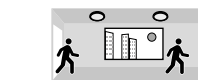

Éteint en cas de lumière du jour suffisante, même après détection.

**2**



100% pendant le temps de rodage, en cas de détection et de lumière du jour insuffisante.

**3**

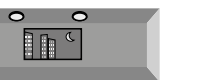

Éteint après le temps de rodage.



#### B Période de stand-by (lumière atténuée)



	6	7	
I	ON	ON	0s
II	ON	—	10min
III	—	ON	30min
IV	—	—	+∞



#### Lumière de jour



	4	5	ON	OFF
I	ON	ON	5Lux	25Lux
II	ON	—	25Lux	75Lux
III	—	ON	50Lux	150Lux
IV	—	—	Disable	Disable



## CAPTEUR MICROWAVE - EXEMPLES DE PARAMETRES

### C 10% / 100%

Toujours activé sur un niveau atténué --> après détection 100% pendant le temps de rodage

**1**

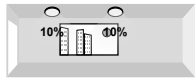

Pendant la journée: niveau atténué.

**2**

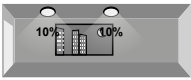



Soir / Nuit: niveau atténué.

**3**



100% pendant le temps de rodage, en cas de détection.



 **Période de stand-by** (Lumière atténuée)

 ON ↑ 

	6	7	
I	ON	ON	0s
II	ON	—	10min
III	—	ON	30min
IV	—	—	+∞

✓

 **Lumière de jour**

 ON ↑ 

	4	5	ON	OFF
I	ON	ON	5Lux	25Lux
II	ON	—	25Lux	75Lux
III	—	ON	50Lux	150Lux
IV	—	—	Disable	Disable

✓

### D 0% / 10% en fonction de la lumière du jour / 100% en fonction du mouvement

Niveau atténué marche / arrêt basé sur la lumière du jour et 100% en cas de la détection

**1**

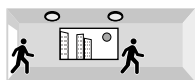

Éteint en cas de suffisamment de lumière du jour, même après détection.

**2**

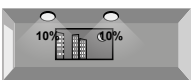

Le soir/la nuit: activé a niveau atténué.

**3**



100% pendant le temps de rodage, en cas de détection.

**5**



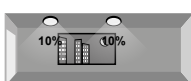

Éteint en cas de suffisamment de lumière du jour, même après détection.

**4**



Le soir/la nuit: activé a niveau atténué.



 **Période de stand-by** (Lumière atténuée)

 ON ↑ 

	6	7	
I	ON	ON	0s
II	ON	—	10min
III	—	ON	30min
IV	—	—	+∞

✓

 **Lumière de jour**

 ON ↑ 

	4	5	ON	OFF
I	ON	ON	5Lux	25Lux
II	ON	—	25Lux	75Lux
III	—	ON	50Lux	150Lux
IV	—	—	Disable	Disable

✓  
✓  
✓

## FONCTION MAÎTRE / ESCLAVE

### Fonction A

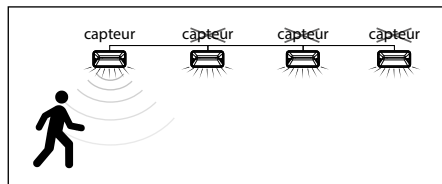

### Fonction B

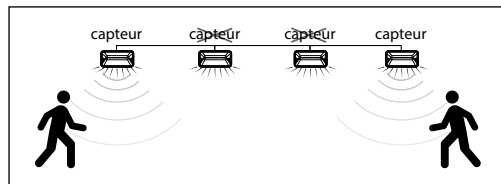

### Fonction A - Commutation centralisée

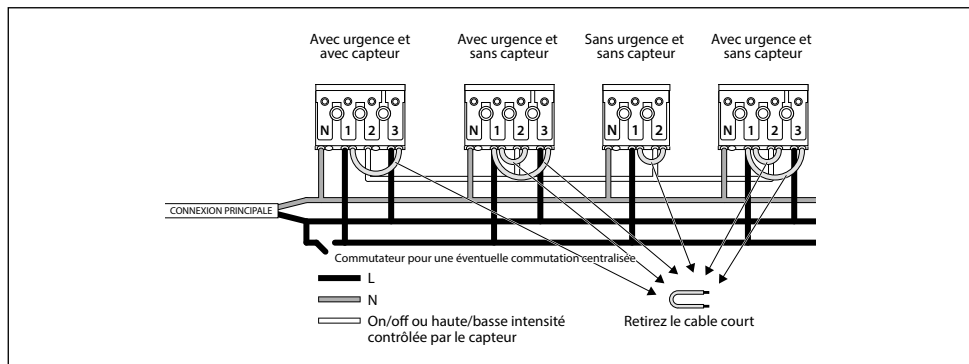

### Fonction B - Seulement commuté au moyen de capteurs intégrés

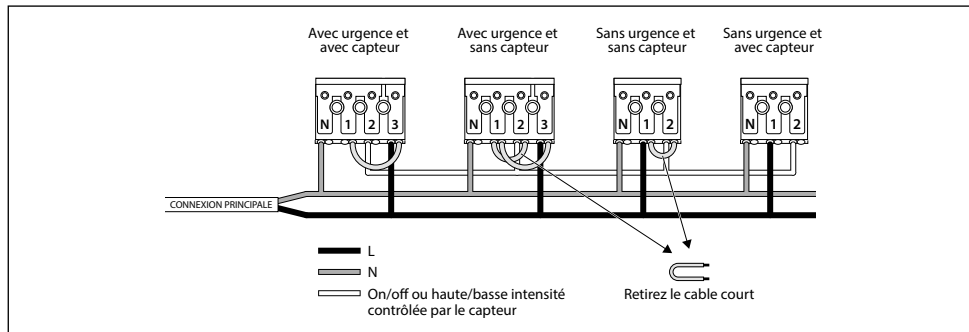

**Le nombre d'unités dans la fonction esclave est limité. (Max 30 pièces)**

## CHOIX DE LA TEMPÉRATURE DE COULEUR

Vous pouvez régler le luminaire sur 2 températures de couleur différentes. L'interrupteur se trouve à côté du module LED et peut être vu lorsque vous avez retiré le capuchon de protection.

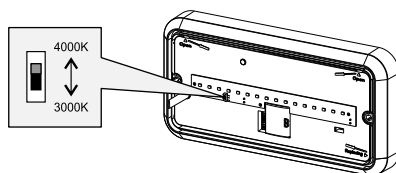

## CHOIX DE LA SORTIE DE LUMIÈRE

Vous pouvez définir l'appareil à 2 valeurs Lumen différentes:

ON - 100% (standard)

1 - 50%

L'interrupteur se trouve à côté du module LED et peut être vu lorsque vous avez retiré le capuchon de protection.

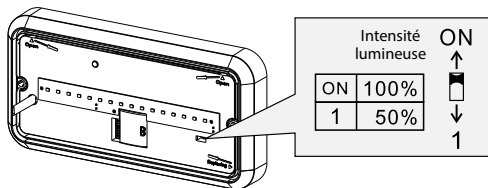

## INSTALLATION

1. Dévissez le blindage et ouvrez le panneau LED.
2. Passer le câble à travers le thule et le fixer avec le réducteur de tension.
3. Fixez l'appareil au moyen de vis sur la surface.  
(Notez la direction. Ceci est indiqué par le marquage 'UP' sur la base du luminaire.)
4. Connectez le câble de connexion au terminal correctement.
5. Branchez la fiche de la batterie à la connexion "Battery +/-" de l'unité d'urgence. ⚠
6. Fermez le panneau LED et fixez le blindage

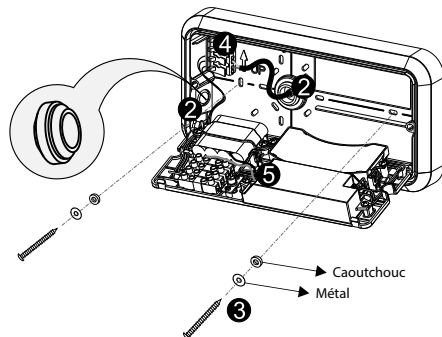
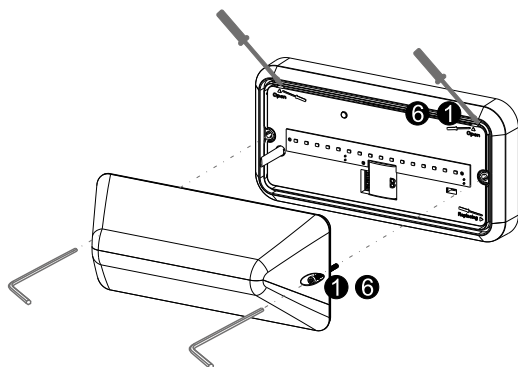

### 4 Câble de connexion

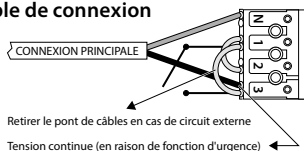

Version d'urgence

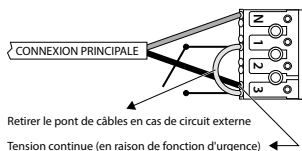

Urgence + version du capteur  
(phase commutée non requise)

## TESTER

Testez la fonction d'urgence après l'installation.

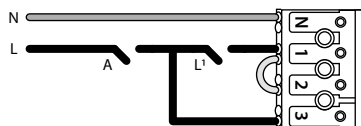

L, N = Alimentation continue  
L' = Alimentation à découpage  
A = Vérification de la fonction d'urgence

## REEMPLACER LA BATTERIE

1. Mettez d'abord le luminaire hors tension.
2. Retirez la fiche de la batterie de l'unité d'urgence.
3. Retirez les attaches en plastique.
4. Retirez la vieille batterie.
5. Notez la date de mise en service de la batterie.
6. Fixez la nouvelle batterie en utilisant les fixations en plastique.
7. Connectez la fiche à l'unité d'urgence.

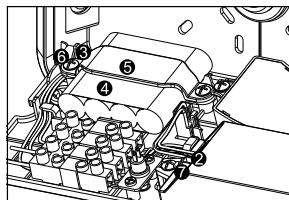

## REEMPLACER LE TRAVAIL INTÉRIEUR

 **Mettez d'abord le luminaire hors tension.**

1. Détachez le capuchon de protection, puis retirez le pilote LED avec un tournevis.
2. Séparez les fiches mâle-femelle et retirez l'ancien travail intérieur.
3. Installez le nouveau travail intérieur puis branchez fermement les fiches mâles-femelles.
4. Fixez le capuchon de protection.

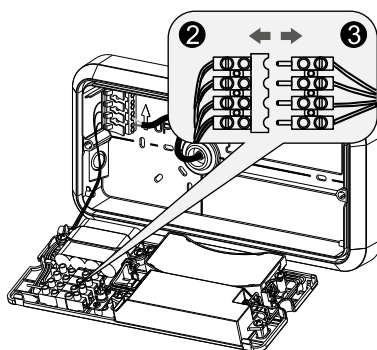
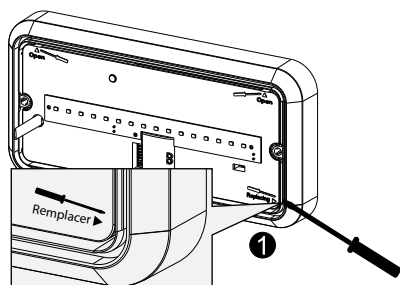

## ENTRETIEN

1. Couper la tension du luminaire.
2. Ne touchez pas les LED pendant l'entretien ou le nettoyage.
3. N'utilisez pas de produits de nettoyage chimiques pour nettoyer le luminaire.

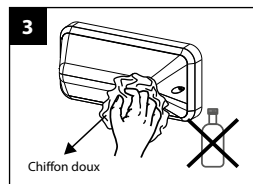
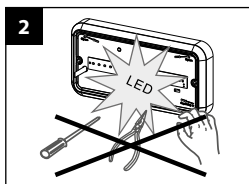
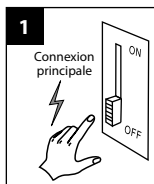

## PROTECTION DE L'ENVIRONNEMENT

Les appareils électriques défectueux ne doivent pas être jetés avec les ordures ménagères. Recycler si possible. Contactez votre municipalité ou votre fournisseur pour obtenir des conseils spécialisés en matière de recyclage.



## UPOZORNĚNÍ

**Prosíme, přečtěte si pozorně návod k použití před začátkem instalace. Tento návod k použití si uchovejte pro případnou budoucí potřebu.**

## UPOZORNĚNÍ

1. Instalace může být provedena pouze kvalifikovaným pracovníkem. Přívod proudu musí být odpojen před začátkem instalace.
2. Průřez vodičů připojovacího vedení musí být min.  $2 \times 1,0 \text{ mm}^2$  a zapojení dle IEE mezinárodních elektrických regulací.
3. Odpojte přívod elektrického proudu před výměnou baterie.
4. Nedotýkejte se elektrického obvodu a jeho komponentů.
5. Při poškození či nefunkčnosti LED osvětlení je nutná výměna celého svítidla.
6. Pokud svítidlo nesvítilí minimálně 1 hodinu při provozu na baterii, baterie musí být vyměněna.
7. Kód pro identifikaci výroby baterie: např. 1810= 2018, týden 10.
8. Nedotýkejte se LED diod během instalace ani při údržbě.
9. LED zdroj svítidla nemůže být vyměněn. Při poruše musí být vyměněno celé svítidlo.
10. Pokud baterie není připojena k hlavnímu zdroji napětí dochází k vybití a tím i snížení kapacity baterie. Delší odpojení od zdroje může baterii poškodit. Při porušení této zásady nelze uznat záruku.
11. Během výstavby mohou být elektrické okruhy opakovaně odpojovány, čímž je způsobeno časté nabíjení a vybití baterie vedoucí ke snížení životnosti a může způsobit i její předčasné selhání. Reklamacie týkající se baterie používané za těchto podmínek jsou výslovně vyloučeny z podmínek záruky.

## TECHNICKÁ DATA

Napájení: AC 220-240V 50/60Hz

Světelný zdroj: LED SMD2835

Baterie: Ni-Cd Výdrž: 1h

Provozní teplota:  $-10^{\circ}\text{C}$  -  $+50^{\circ}\text{C}$  (Verze s čidlem: max.  $+40^{\circ}\text{C}$ )

Třída ochrany: Třída II

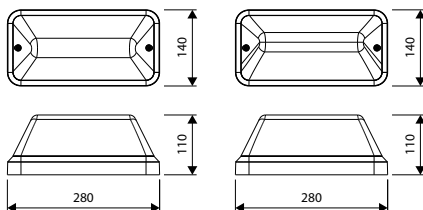

## TECHNICKÉ INFORMACE

### Standardní verze

Obj.č.	Barva	Příkon	Světelný tok přepínatelné	Senzor
40010302	Bílá	7W	700Lm / 350Lm	-
40010312	Černá	7W	700Lm / 350Lm	-
40010303	Bílá	8W	700Lm / 350Lm	Ano
40010313	Černá	8W	700Lm / 350Lm	Ano

### Verze s částečným stíněním

Obj.č.	Barva	Příkon	Světelný tok přepínatelné	Senzor
40010322	Bílá	7W	500Lm / 250Lm	-
40010332	Černá	7W	500Lm / 250Lm	-
40010323	Bílá	8W	500Lm / 250Lm	Ano
40010333	Černá	8W	500Lm / 250Lm	Ano

## MIKROVLNNÝ SENZOR - POPIS

Detekční zóna max. (š x v): 12m x 6m

Citlivost detekce: 50% nebo 100% - nastavitelné

Doba plného osvětlení: 5s - 10min - nastavitelné

Denní osvětlení zap.: 5 - 50Lux, nastavitelné nebo vyp.

Denní osvětlení vyp.: 25 - 150Lux, nastavitelné nebo vyp.

Pohotovostní režim (nízká míra osvětlení):

0 s -  $+\infty$  min, nastavitelné

Stupeň stmívání v pohotovostním režimu:

10% or 25%, nastavitelné

Výška stropní montáže: 6m max.

Detektor pohybu (práh): 0.3 ~ 3m/s

Úhel detekce:  $150^{\circ}$  (nástěnná montáž),

$360^{\circ}$  (stropní montáž)

Oblast detekce při stropní montáži (m)  
Doporučená montážní výška: 3m

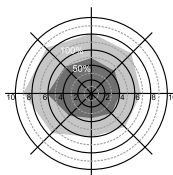

Rychlost pohybu: 0,3m/s

Oblast detekce při nástěnné montáži (m)  
Doporučená montážní výška: 2m

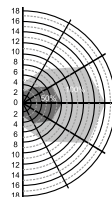

Rychlost pohybu: 0,3m/s

## NASTAVENÍ PARAMETRŮ MV SENZORU

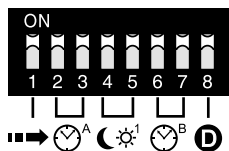

### Oblast detekce

To určuje efektivní dosah detektoru pohybu a nastavuje se pomocí DIP switch přepínačů na ovladači. Pamatujte, že snížení citlivosti také zúží rozsah detekce.

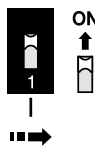

	1	
I	ON	100%
II	—	50%

### Doba plného osvětlení

Určuje dobu, po kterou zařízení zůstane nastaveno na 100% osvětlení a je nastaveno pomocí přepínačů DIP switch na ovladači. Nastavení testu chůze (5 s) je užitečné při instalaci zařízení pro zajištění správné funkce a dosahu.

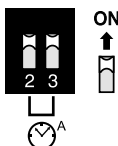

	2	3	
I	ON	ON	5s
II	ON	—	1min
III	—	ON	5min
IV	—	—	10min

### Režim denního osvětlení

S tímto nastavením lze určit na jaké úrovni denního světla se svítidlo zapne nebo naopak nespustí, když je detekován pohyb. Funkci fotobuňky lze také deaktivovat.

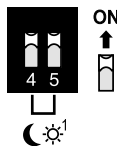

	4	5	ON	OFF
I	ON	ON	5Lux	25Lux
II	ON	—	25Lux	75Lux
III	—	ON	50Lux	150Lux
IV	—	—	Disable	Disable

### Pohotovostní režim

S nastavením +∞ se zařízení rozsvítí tlumeně na základě nastavení ☾ a míře okolního osvětlení. S detekcí pohybu se míra osvětlení během doby stand by zvýší na 100%.

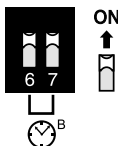

	6	7	
I	ON	ON	0s
II	ON	—	10min
III	—	ON	30min
IV	—	—	+∞

### D Stupeň stmívání v pohotovostním režimu

Úprava světelného toku s úrovní tlumeného světla.

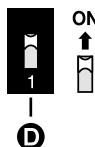

	8	
I	ON	10%
II	—	25%

Když je přepínač DIP switch nastaven na +∞ v „Pohotovostním režimu“, výchozí nastavení je 10% a nelze jej změnit.



## MIKROVLNNÉ ČIDLO – PŘÍKLAD NASTAVENÍ

### A 0% / 100% / 10% nebo 25%

Vypnuto s dostatečným atmosférickým osvětlením -> večer / v noci po detekci pohybu 100% během doby zadržení a 10% / 25% během doby pohotovosti -> poté vypnuto

**1**



Vypnuto s dostatečným denním osvětlením, a to i po detekci pohybu.

**2**



100% během doby osvětlení, při detekci a nedostatečném denním osvětlení.

**3**



Po době osvětlení na 10% / 25% během pohotovostního režimu.

**4**

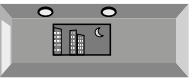

Po skončení pohotovostního režimu vypnuto.

**B** **Pohotovostní doba** (tlumené osvětlení)



	6	7	
I	ON	ON	0s
II	ON	—	10min
III	—	ON	30min
IV	—	—	+∞

**Režim denního osvětlení**



	4	5	ON	OFF
I	ON	ON	5Lux	25Lux
II	ON	—	25Lux	75Lux
III	—	ON	50Lux	150Lux
IV	—	—	Disable	Disable

### B 0% / 100%

Vypnuto s dostatečným atmosférickým osvětlením -> večer / v noci po detekci pohybu 100% během doby osvětlení -> poté vypnuto

**1**

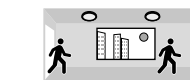

Vypnuto s dostatečným denním osvětlením, a to i po detekci pohybu.

**2**



100% během doby osvětlení, při detekci a nedostatečném denním osvětlení.

**3**

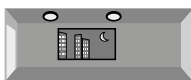

Vypnuto po době osvětlení.

**B** **Pohotovostní doba** (tlumené osvětlení)



	6	7	
I	ON	ON	0s
II	ON	—	10min
III	—	ON	30min
IV	—	—	+∞

**Režim denního osvětlení**



	4	5	ON	OFF
I	ON	ON	5Lux	25Lux
II	ON	—	25Lux	75Lux
III	—	ON	50Lux	150Lux
IV	—	—	Disable	Disable

## MIKROVLNNÉ ČIDLO – PŘÍKLAD NASTAVENÍ

### C 10% / 100%

Vždy zapnuto na tlumené úrovni -> po detekci pohybu 100% během doby osvětlení

**1**

Denní: tlumená úroveň.

**2**

Večer / v noci: tlumená úroveň.

**3**

100% během doby osvětlení, po detekci.

**Pohotovostní doba** (tlumené osvětlení)

	6	7	
I	ON	ON	0s
II	ON	—	10min
III	—	ON	30min
IV	—	—	+∞

✓

**Režim denního osvětlení**

	4	5	ON	OFF
I	ON	ON	5Lux	25Lux
II	ON	—	25Lux	75Lux
III	—	ON	50Lux	150Lux
IV	—	—	Disable	Disable

✓

### D 0% / 10% na základě denního osvětlení / 100% při spuštění

Úroveň stmívání zapnuto / vypnuto na základě denního osvětlení a 100% při detekci pohybu

**1**

Vypnuto s dostatečným denním osvětlením, a to i po detekci pohybu.

**2**

Večer / v noci: zapnuto na tlumené úrovni.

**3**

100% během doby osvětlení, po detekci.

**4**

Večer / v noci: zapnuto na tlumené úrovni.

**5**

Vypnuto s dostatečným denním osvětlením, a to i po detekci pohybu.

**Pohotovostní doba** (tlumené osvětlení)

	6	7	
I	ON	ON	0s
II	ON	—	10min
III	—	ON	30min
IV	—	—	+∞

✓

**Režim denního osvětlení**

	4	5	ON	OFF
I	ON	ON	5Lux	25Lux
II	ON	—	25Lux	75Lux
III	—	ON	50Lux	150Lux
IV	—	—	Disable	Disable

✓  
✓  
✓

## FUNKCE MASTER/SLAVE

### Funkce A

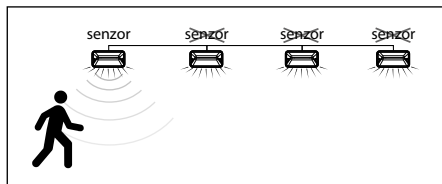

### Funkce B

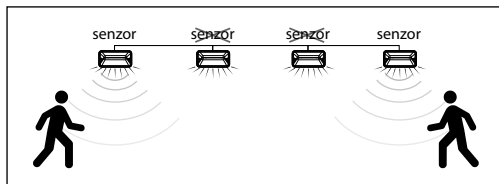

### Funkce A - Centrální spínání

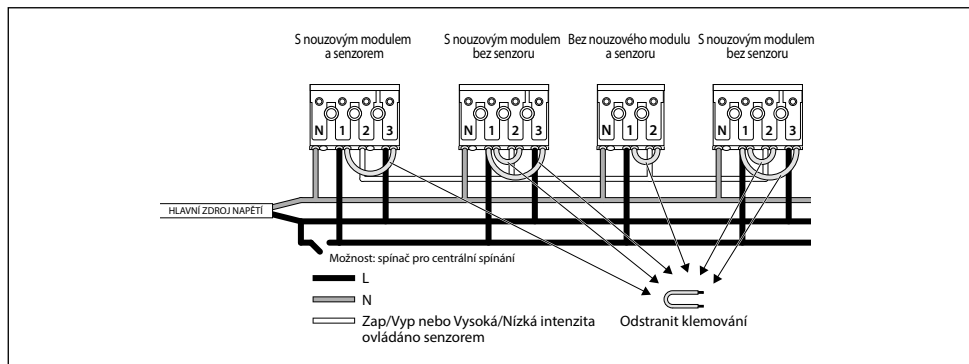

### Funkce B - Spínání pouze pomocí vestavěných čidel

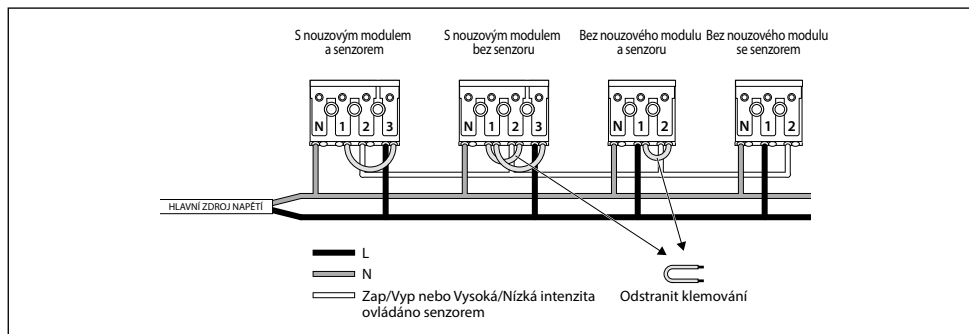

**⚠ Počet svítidel ve funkci Slave je omezen. (Max. 30 ks)**

## VOLITELNÁ TEPLOTA CHROMATIČNOSTI

K dispozici 2 možnosti nastavení teploty chromatičnosti pomocí přepínače umístěného přímo na svítidle.

Přepínač je umístěn vedle LED modulu a je dostupný po odstranění ochranného krytu.

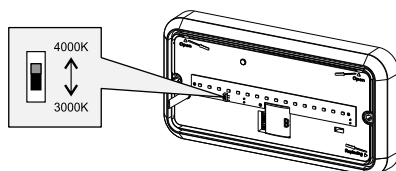

## MOŽNOSTI NASTAVENÍ SVÍTIVOSTI

Volba intenzity svítivosti pomocí přepínače umístěného na desce LED diod:

ON - 100% (standard)

1 - 50%

Přepínač je umístěn vedle LED modulu a je dostupný po odstranění ochranného krytu.

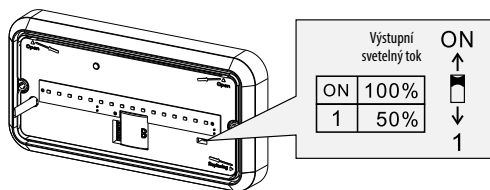

## MONTÁŽ

1. Demontujte difuzor a desku s LED diodami.
2. Protáhněte přívodní kabel otvorem v krytu svítidla.
3. Umístěte svítidlo na požadované místo a zafixujte.  
(Pozor na směr. Ten je označen slovem "UP" na krytu svítidla.)
4. Správně zapojte kabel ke svorce.
5. Připojte pevně baterii k nouzovému modulu. 
6. Nasadte zpět difuzor a desku s diodami.

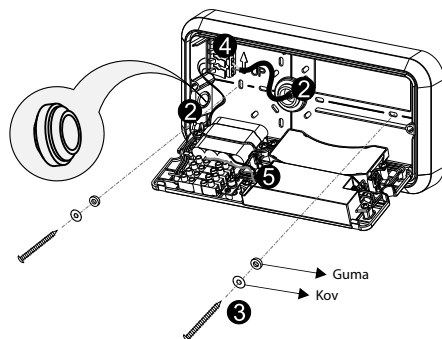
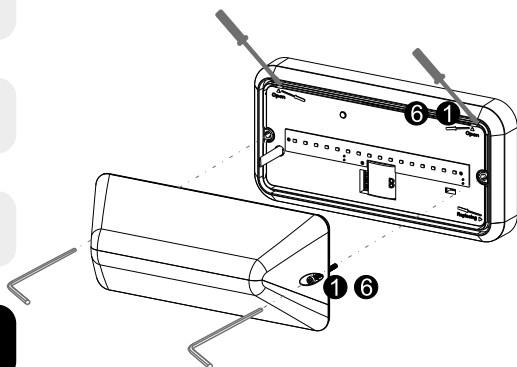

### 4 Připojení vodičů

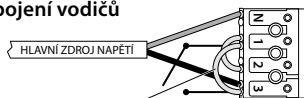

Odstranit klemování pro externí spínání

Přerušení hlavního zdroje napětí ( pro funkci nouzové zálohy)

**Nouzový modul**

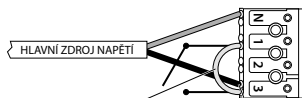

Odstranit klemování pro externí spínání

Přerušení hlavního zdroje napětí ( pro funkci nouzové zálohy)

**Nouzový modul + senzor  
(bez spínače)**

## TEST

Vyzkoušejte nouzovou funkci po instalaci.

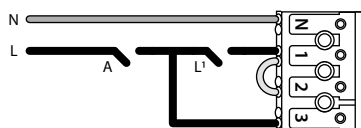

L, N = Napájecí okruh

L' = Spínací okruh

A = Test nouzového modulu

## VÝMĚNA BATERIE

1. Nejprve odpojte přívod napětí.
2. Odpojte baterie od nouzového modulu.
3. Odšroubujte plastové úchyty.
4. Odstraňte původní baterie.
5. Zaznamenejte si datum výměny baterií.
6. Připevňte nové baterie plastovými úchyty.
7. Připojte baterie k nouzovému modulu.

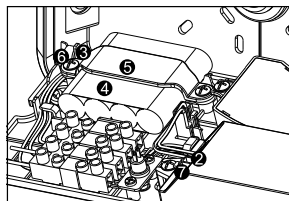

## VÝMĚNA ZDROJE SVĚTLA

**!** Nejprve odpojte přívod napětí.

1. Otevřete difuzor, poté pomocí nástroje demontujte desku s LED diodami.
2. Oddělte svorku a vyjměte původní desku s LED diodami.
3. Připojte novou LED desku.
4. Nasadte difuzor.

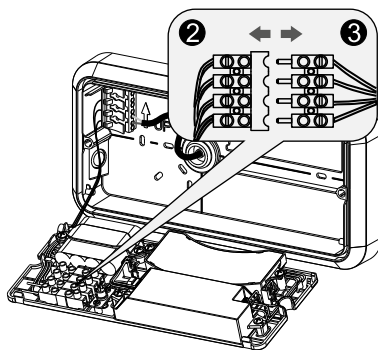
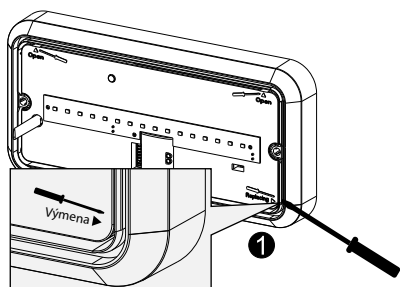

## ÚDRŽBA

1. Nejprve vypněte přívod proudu.
2. Nedotýkejte se LED diod při údržbě ani čištění.
3. Nepoužívejte chemické čisticí prostředky.

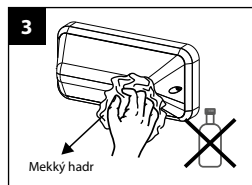
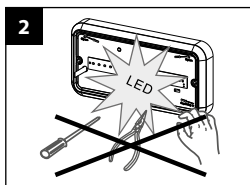

## OCHRANA ŽIVOTNÍHO PROSTŘEDÍ

Vyřazené elektronické přístroje nepatří do směšného odpadu. Prosíme recyklujte na místech tomu určených. Případně se poraďte s místním úřadem nebo svým prodejcem.



## ACHTUNG

Lesen Sie die folgende Anleitung bitte aufmerksam durch, um eine korrekte Ausführung der Montage zu gewährleisten. Bewahren Sie diese Anleitung zum späteren Nachschlagen gut auf.

## HINWEIS

- Das Produkt muss durch einen qualifizierten Techniker installiert werden. Die Installation muss, vor der Montage, bei abgeschalteter Versorgungsspannung vorgenommen werden.
- Die Leitung zur Spannungsversorgung muss einen Mindestquerschnitt von  $2 \times 1,0 \text{ mm}^2$  aufweisen und entsprechend den neusten IEE-Vorschriften oder den nationalen Vorschriften angeschlossen sein.
- Schalten Sie die Spannungsversorgung des Treibers ab, bevor Sie den Akku austauschen.
- Elektronische Schaltung und zugehörige Teile nicht berühren.
- Falls eine Leuchtdauer von 1 Stunde nicht mehr erreicht wird, muss der Akku ausgetauscht werden.
- Wenden Sie sich an den autorisierten Kundendienst, um den Akku austauschen zu lassen und verwenden Sie für andere Reparaturen nur Originalersatzteile.
- ID-Code zum Herstellungsdatum des Akkus: z. B. 1810 – 2018, Woche 10.
- LEDs bei Installation und Wartung nicht berühren.
- Die LED-Lichtquelle kann nicht ausgetauscht werden. Wenn die Lichtquelle ausfällt, muss das gesamte Gerät ausgetauscht werden.
- Durch Selbstentladung nimmt die Ladung des Akkus langsam ab, wenn das Gerät nicht mit dem Netz verbunden ist. Bei längerer Spannungslosigkeit kann der Akku beschädigt werden. Hierdurch verursachte Schäden fallen nicht unter die Garantie.
- Auf vielen Baustellen können Stromkreise während der Bauarbeiten unkontrolliert und wiederholt unterbrochen werden. Dadurch können sich die Akkus entladen. Häufiges Laden und Entladen eines Akkus verkürzt seine Lebensdauer und kann zum vorzeitigen Ausfall führen. Hierdurch verursachte Schäden fallen nicht unter die Garantie.

## TECHNISCHE DATEN

Betriebsspannung: AC 220-240V 50/60Hz

Lichtquelle: SMD2835 LED

Akku: Ni-Cd Leuchtdauer: 1 h

Betriebstemperatur:  $-10^\circ\text{C} - +50^\circ\text{C}$  (Sensorausführung): bis max.  $+40^\circ\text{C}$

Schutzklasse: Klasse II

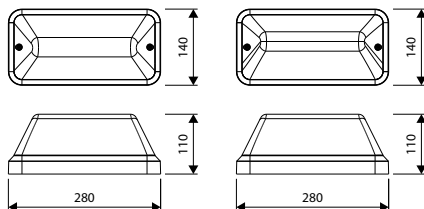

## TECHNISCHE INFORMATIONEN

### Standard Version

Artikelnr.	Farbe	Leistung	Lichtstrom schaltbar	Sensor
40010302	Weiß	7W	700Lm / 350Lm	-
40010312	Schwarz	7W	700Lm / 350Lm	-
40010303	Weiß	8W	700Lm / 350Lm	Ja
40010313	Schwarz	8W	700Lm / 350Lm	Ja

### Halb abgeschirmte Version

Artikelnr.	Farbe	Leistung	Lichtstrom schaltbar	Sensor
40010322	Weiß	7W	500Lm / 250Lm	-
40010332	Schwarz	7W	500Lm / 250Lm	-
40010323	Weiß	8W	500Lm / 250Lm	Ja
40010333	Schwarz	8W	500Lm / 250Lm	Ja

## MIKROWELLEN-SENSOR - BESCHREIBUNG

Ansprechbereich max. (T x H): 12m x 6m

Ansprechempfindlichkeit: 50% oder 100%, einstellbar

Leuchtdauer: 5sec - 10 Minuten, einstellbar

Tageslicht an: 5 - 50Lux, einstellbar oder ausschalten

Tageslicht aus: 25 - 150Lux, einstellbar oder ausschalten

Nachlaufzeit (Orientierungsbeleuchtung):

0 sec -  $+\infty$  min (einstellbar)

Orientierungsbeleuchtung: 10% oder 25% (einstellbar)

Montagehöhe: max. 6 m

Bewegungserkennung: 0.3 ~ 3m/s

Erkennungswinkel:  $150^\circ$  (Wandmontage),

$360^\circ$  (Deckenmontage)

Ansprechbereich (m) Deckenmontage  
Empfohlene Montagehöhe: 3m

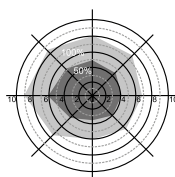

Bewegungsgeschwindigkeit: 0,3m/s

Ansprechbereich (m) Wandmontage  
Empfohlene Montagehöhe: 2m

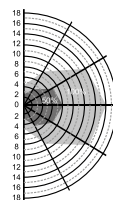

Bewegungsgeschwindigkeit: 0,3m/s

## MIKROWELLEN-SENSOR - EINSTELLEN DER PARAMETER

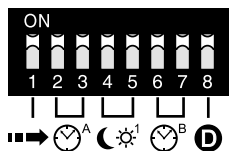

### Ansprechbereich

Diese Einstellung bestimmt den Ansprechbereich des Bewegungsmelders. Hierzu dienen die DIP-Schalter am Sensor, siehe Abbildung unten. Beachten Sie bitte, dass sich bei geringerer Empfindlichkeit auch der Ansprechbereich verkleinert.

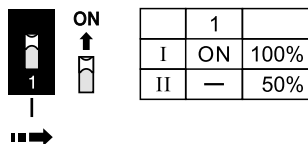

### Laufzeit

Dies ist die Zeit, während der die Leuchte mit 100% Helligkeit leuchtet. Die Einstellung erfolgt an den DIP-Schaltern am Sensor, siehe Abbildung unten. Während der Installation der Leuchte ist die Einstellung Laufzeit (5s) eine praktische Hilfe, um die korrekte Funktion im gewünschten Bereich zu überprüfen.

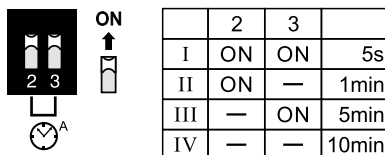

### Tageslicht

Mit dieser Einstellung kann bestimmt werden, bei welchem Tageslichtniveau die Leuchte eingeschaltet wird oder nicht, wenn eine Bewegung erkannt wird. Die Photozellenfunktion kann auch deaktiviert werden.

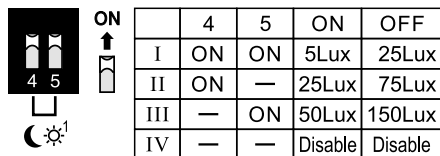

### Nachlaufzeit, Orientierungsbeleuchtung

Mit der +∞-Einstellung Leuchtkraft bei 10%/25% abhängig von der ☀️-Einstellung, bei Bewegungserkennung 100% während der Laufzeit.

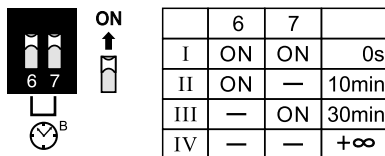

### Standby-Dimmstufe

Einstellung des Lichtstroms bei gedimmtem Lichtniveau.

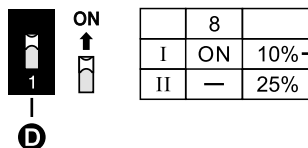

Wenn der DIP-Schalter auf +∞ bei 'Nachlaufzeit, Orientierungsbeleuchtung' eingestellt ist, beträgt die Standardeinstellung 10% und kann nicht geändert werden.

# MIKROWELLEN-SENSOR - BEISPIELE FÜR EINSTELLUNGEN

## A 0% / 100% / 10% oder 25%

AUS bei ausreichendem Umgebungslicht --> abends / nachts bei Bewegungserkennung 100% und während der Nachlaufzeit 10%/25% --> danach AUS

**1**

AUS bei ausreichendem Tageslicht, auch nach der Bewegungserkennung.

**2**

100% während der Laufzeit, bei Bewegungserkennung und unzureichendem Tageslicht.

**3**

Nach der Laufzeit auf 10%/25% während der Nachlaufzeit.

**4**

AUS nach dem Ende der Nachlaufzeit.

**Nachlaufzeit, Orientierungsbeleuchtung**

ON ↑

	6	7	
I	ON	ON	0s
II	ON	—	10min
III	—	ON	30min
IV	—	—	+∞

✓ ✓

**Tageslicht**

ON ↑

	4	5	ON	OFF
I	ON	ON	5Lux	25Lux
II	ON	—	25Lux	75Lux
III	—	ON	50Lux	150Lux
IV	—	—	Disable	Disable

☀️<sup>1</sup>

✓ ✓ ✓

## B 0% / 100%

AUS bei ausreichendem Umgebungslicht --> abends / nachts bei Bewegungserkennung 100% --> danach AUS

**1**

AUS bei ausreichendem Tageslicht, auch nach der Bewegungserkennung.

**2**

100% während der Laufzeit, bei Bewegungserkennung und unzureichendem Tageslicht.

**3**

AUS nach Laufzeit

**Nachlaufzeit, Orientierungsbeleuchtung**

ON ↑

	6	7	
I	ON	ON	0s
II	ON	—	10min
III	—	ON	30min
IV	—	—	+∞

✓

**Tageslicht**

ON ↑

	4	5	ON	OFF
I	ON	ON	5Lux	25Lux
II	ON	—	25Lux	75Lux
III	—	ON	50Lux	150Lux
IV	—	—	Disable	Disable

☀️<sup>1</sup>

✓ ✓ ✓



# MIKROWELLEN-SENSOR - BEISPIELE FÜR EINSTELLUNGEN

## C 10% / 100%

Leuchte ist immer gedimmt (10%/25 %) --> abends / nachts bei Bewegungserkennung 100%

**1**

Tagsüber:  
auf 10%/25% gedimmt

**2**

Abends/nachts:  
auf 10%/25% gedimmt

**3**

Bei Bewegungserkennung,  
100% während der Laufzeit

**B** Nachlaufzeit, Orientierungsbeleuchtung **1** Tageslicht

ON ↑	6	7		
6 7	I	ON	ON	0s
⌚ <sup>B</sup>	II	ON	—	10min
	III	—	ON	30min
	IV	—	—	+∞

☀️<sup>1</sup> Tageslicht

ON ↑	4	5	ON	OFF
4 5	I	ON	ON	5Lux 25Lux
☀️ <sup>1</sup>	II	ON	—	25Lux 75Lux
	III	—	ON	50Lux 150Lux
	IV	—	—	Disable Disable

## D 0% / 10% basierend auf Tageslicht / 100% bei Bewegungserkennung

Leuchte gedimmt basierend auf Tageslicht und bei Bewegungserkennung 100% während der Laufzeit

**1**

AUS bei ausreichendem Tageslicht, auch nach  
der Bewegungserkennung.

**2**

Abends/nachts:  
auf 10%/25% gedimmt

**3**

Bei Bewegungserkennung,  
100% während der Laufzeit



**5**

AUS bei ausreichendem Tageslicht, auch nach  
der Bewegungserkennung.

**4**

Abends/nachts:  
auf 10%/25% gedimmt

**B** Nachlaufzeit, Orientierungsbeleuchtung **1** Tageslicht

ON ↑	6	7		
6 7	I	ON	ON	0s
⌚ <sup>B</sup>	II	ON	—	10min
	III	—	ON	30min
	IV	—	—	+∞

☀️<sup>1</sup> Tageslicht

ON ↑	4	5	ON	OFF
4 5	I	ON	ON	5Lux 25Lux
☀️ <sup>1</sup>	II	ON	—	25Lux 75Lux
	III	—	ON	50Lux 150Lux
	IV	—	—	Disable Disable

## MASTER/SLAVE FUNKTION

### Funktion A

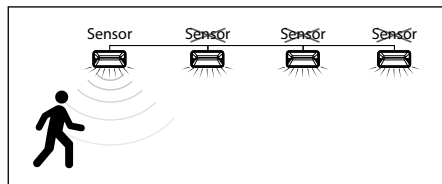

### Funktion B

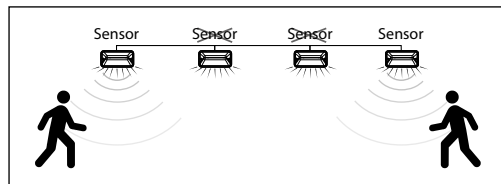

### Funktion A - Zentral geschaltet

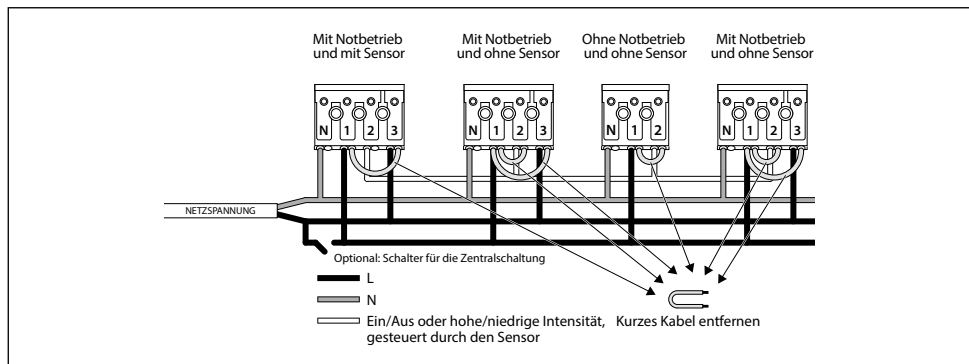

### Funktion B - Nur über eingebaute Sensoren schaltbar

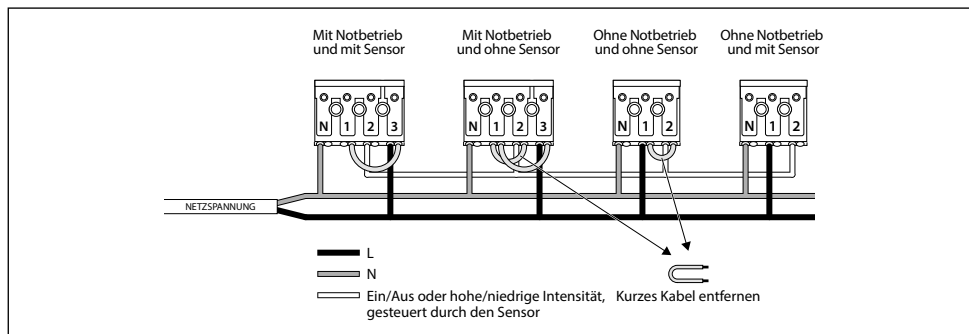

**⚠ Die Anzahl der Slaves ist begrenzt. (Max. 30 Stück)**

## AUSWAHL DER FARBTEMPERATUR

Es gibt 2 mögliche Farbtemperaturen, die über einen Schalter auf dem LED-Panel eingestellt werden können.

Der Schalter befindet sich auf dem LED-Panel und wird nach Abnehmen der Blende zugänglich.

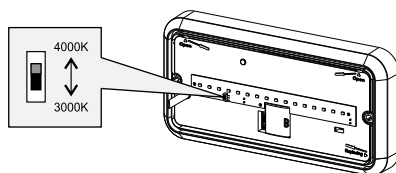

## AUSWAHL DER HELLIGKEIT

Sie können an der Leuchte zwei verschiedene Lumen-Werte einstellen:

- ON - 100% (Standard)
- 1 - 50%

Der Schalter befindet sich neben dem LED-Modul und wird nach Abnehmen der Blende zugänglich.

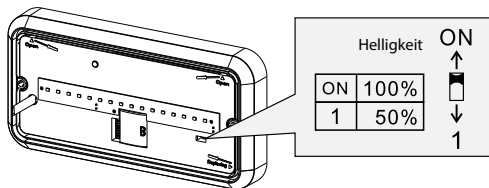

## MONTAGE

1. Schrauben Sie die Blende ab und öffnen Sie das LED-Panel.
2. Führen Sie das Anschlusskabel durch die Tülle und fixieren Sie es mit der Zugentlastung.
3. Befestigen Sie die Leuchte mit Schrauben auf der Montagefläche.  
(Achten Sie auf die richtige Ausrichtung. Diese wird durch die "UP"-Markierung auf der Unterseite der Leuchte angegeben.)
4. Schließen Sie das Anschlusskabel korrekt an den Klemmen an.
5. Verbinden Sie den Stecker des Akkus mit dem Anschluss "Battery +/-" an der Notstromversorgung. ⚠
6. Schließen Sie das LED-Panel und befestigen Sie die Blende.

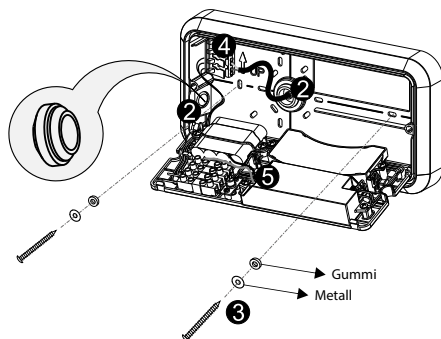
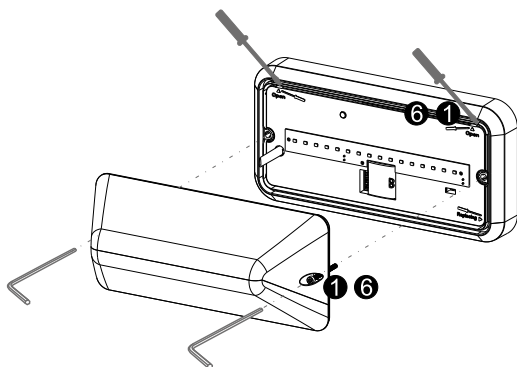

### 4 Anschluss des Kabels

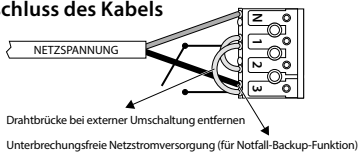

Version mit Notbetrieb

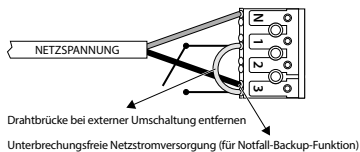

Version mit Notbetrieb und Sensor  
(geschaltete Phase nicht unbedingt erforderlich)

## TESTS

Tests des Notbetriebs nach der Installation.

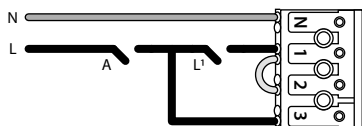

- L, N = Nicht geschaltete Spannungsversorgung
- L' = Geschaltete Spannungsversorgung
- A = Kontrolle des Notbetriebs

## AKKU AUSTAUSCHEN

1. Spannungsversorgung der Leuchte unterbrechen.
2. Stecker des Akkus aus der Notstromversorgung ziehen.
3. Kunststoffhalter entfernen.
4. Alten Akku entnehmen.
5. Datum der Inbetriebnahme des Akkus notieren.
6. Neuen Akku mit den Kunststoffhaltern befestigen.
7. Stecker mit der Notstromversorgung verbinden.

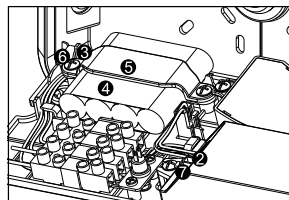

## KOMPONENTEN IM INNEREN AUSTAUSCHEN

### ! Spannungsversorgung der Leuchte unterbrechen.

1. Blende lösen, anschließend mit einem Schraubendreher den LED-Treiber entfernen.
2. Stecker und Kupplung trennen und alte Komponenten im Inneren entfernen.
3. Neue Komponenten im Inneren montieren und Stecker und Kupplung fest miteinander verbinden.
4. Blende anbringen.

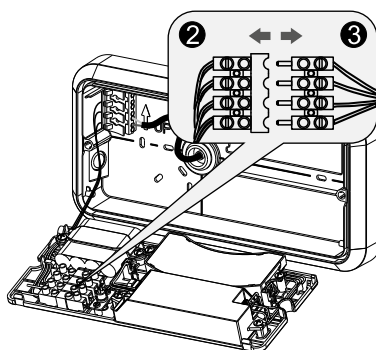
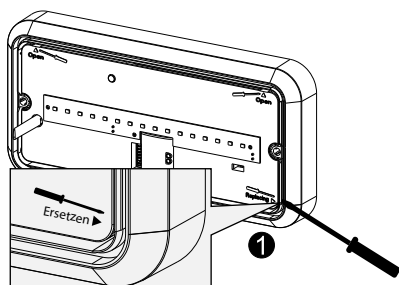

## WARTUNG

1. Spannungsversorgung der Leuchte unterbrechen.
2. LEDs bei Installation und Wartung nicht berühren.
3. Zur Reinigung der Leuchte keine Chemikalien verwenden.

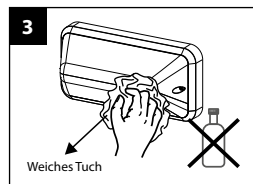
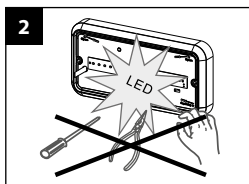

## UMWELTSCHUTZ

Defekte Elektrogeräte dürfen nicht über den Hausmüll entsorgt werden. Führen Sie sie, falls möglich, dem Recycling zu. Für weitere Hinweise zum Recycling wenden Sie sich bitte an Ihre Gemeinde oder Ihren Lieferanten.









# PROLUMIA®

## IMPORTER

### **NEDELKO B.V.**

Riga 10

2993 LW BARENDRECHT

**T** +31 (0)180 64 54 00

**E** info@nedelko.nl

### **NEDELKO BELGIUM NV**

Prins Boudewijnlaan 49

2650 EDEGEM

**T** +32 (0)3 826 99 99

**E** info@nedelko.be

### **NEDELKO S.R.O.**

Purkyňova 74/2

110 00 PRAHA 1 - NOVÉ MĚSTO

**T** +420 222 563 003

**E** info@nedelko.cz

### **NEDELKO GERMANY GMBH**

Heinz-Bäcker-Str. 27

45356 ESSEN

**T** +49 (0)201 560503 50

**E** info@nedelko.de